

патрон открыт

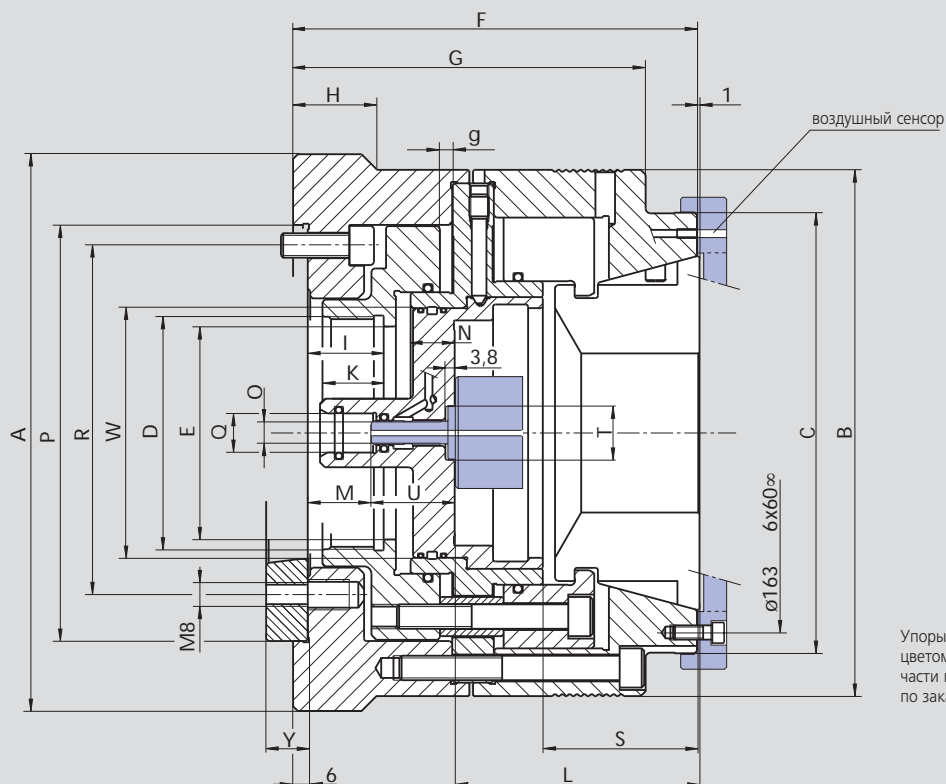

возможны изменения

Упоры, показанные голубым цветом, (внутри и на лицевой части патрона) поставляются по заказу.

SMW-AUTOBLOK тип		KSZ-AZL 100											
тип крепления		Z170			Z220			A6			A8		
ид. No.		194741			195244			194783			195245		
A		215			230			215			230		
B		-			215			-			215		
C		180			180			180			180		
D		M95 x 2			M115x2			M95x2			M115x2		
E		87			107			87			107		
F		165			165			176			178		
G		144			144			155			157		
H		-			37			-			37		
I		36			36			36			36		
K		25			25			25			25		
L		99			99			99			99		
M		25			25			25			25		
N		17			17			17			17		
O		M12			M12			M12			M12		
R _{н6}		170			220								
Q		16			16			16			16		
R		133.4	6x60°	M12	171.4	6x60°	M16	133.4	6x60°	M12	171.4	6x60°	M16
S		63			63			63			63		
T		22			22			22			22		
U		34.3			34.3			34.3			34.3		
V		M12			M12			M12			M12		
W		102			102			102			102		
X		111			111			111			111		
Y		-			-			17			19		
ход	g	9			9			9			9		
допустимая частота вращ.	об/мин	5000			5000			5000			5000		
макс. приводное усилие	daN	6500			6500			6500			6500		
макс. усилие зажима	daN	8500			8500			8500			8500		
масса без цанг	kg	33			35			34			36		
приводной цилиндр	тип	VNK 200-86			VNK 225-95 / VNK 250-110			VNK 200-86			VNK 225-95 / VNK 250-110		
частота вращения	об/мин	4500			4000 / 3600			4500			4000 / 3600		

Комплект поставки: Патрон и крепежные болты



тип крепления	размер	KSZ-AZL 100
Z 170		194741
A 06		194783
Z 220		195244
A 08		195245

Приспособление для смены цанг



приспособление	размер	KSZ-AZL 100
пневматическое		194744

Цанги для KSZ-AZL

стальные цанги с осевыми и поперечными канавками

КРУГЛЫЕ*

Ø	42	43	44	45	46	47	48	49	50	51	52	53	54
ид. No.	195081	195082	195083	195084	195085	195086	195087	195088	195089	195090	195091	195092	195093
Ø	55	56	57	58	59	60	61	62	63	64	65	66	67
ид. No.	195094	195095	195096	195097	195098	195099	195100	195101	195102	195103	195104	195105	195106
Ø	68	69	70	71	72	73	74	75	76	77	78	79	80
ид. No.	195107	195108	195109	195110	195111	195112	195113	195114	195115	195116	195117	195118	195119
Ø	81	82	83	84	85	86	87	88	89	90	91	92	93
ид. No.	195120	195121	195122	195123	195124	195125	195126	195127	195128	195129	195130	195131	195132
Ø	94	95	96	97	98	99	100						
ид. No.	195133	195134	195135	195136	195137	195138	194742						

стальные цанги с гладкой зажимной поверхностью

КРУГЛЫЕ*

Ø	42	43	44	45	46	47	48	49	50	51	52	53	54
ид. No.	195141	195142	195143	195144	195145	195146	195147	195148	195149	195150	195151	195152	195153
Ø	55	56	57	58	59	60	61	62	63	64	65	66	67
ид. No.	195154	195155	195156	195157	195158	195159	195160	195161	195162	195163	195164	195165	195166
Ø	68	69	70	71	72	73	74	75	76	77	78	79	80
ид. No.	195167	195168	195169	195170	195171	195172	195173	195174	195175	195176	195177	195178	195179
Ø	81	82	83	84	85	86	87	88	89	90	91	92	93
ид. No.	195180	195181	195182	195183	195184	195185	195186	195187	195188	194743	195189	195190	195191
Ø	94	95	96	97	98	99	100						
ид. No.	195192	195193	195194	195195	195196	195197	195198						

*концентричность подобна DIN 6343

